

W White-Westinghouse

INTERNATIONAL

Factory Parts Catalog

Product No.	WSPZ25V9CSP	WSPZ25V9CS7
Series	R134a System	R134a System
Color	stain/blk	stain/blk
Volts	220	220
Wiring Diagram	241594301	241594301
Owner's Guide	240417300	240417300
Market	Export	Export
Service Data Sheet	240420909	240420909

INTERNATIONAL
3 Parkway Center, Pittsburgh, PA 15220

Publication No.
5995446357
05/08/30
(EN/SERVICE/WC)
357

SIDE-BY-SIDE REFRIGERATOR

Model No.
WSPZ25V9C

Copyright © 2005 Electrolux Home Products, Inc.
All rights reserved.

FREEZER DOOR

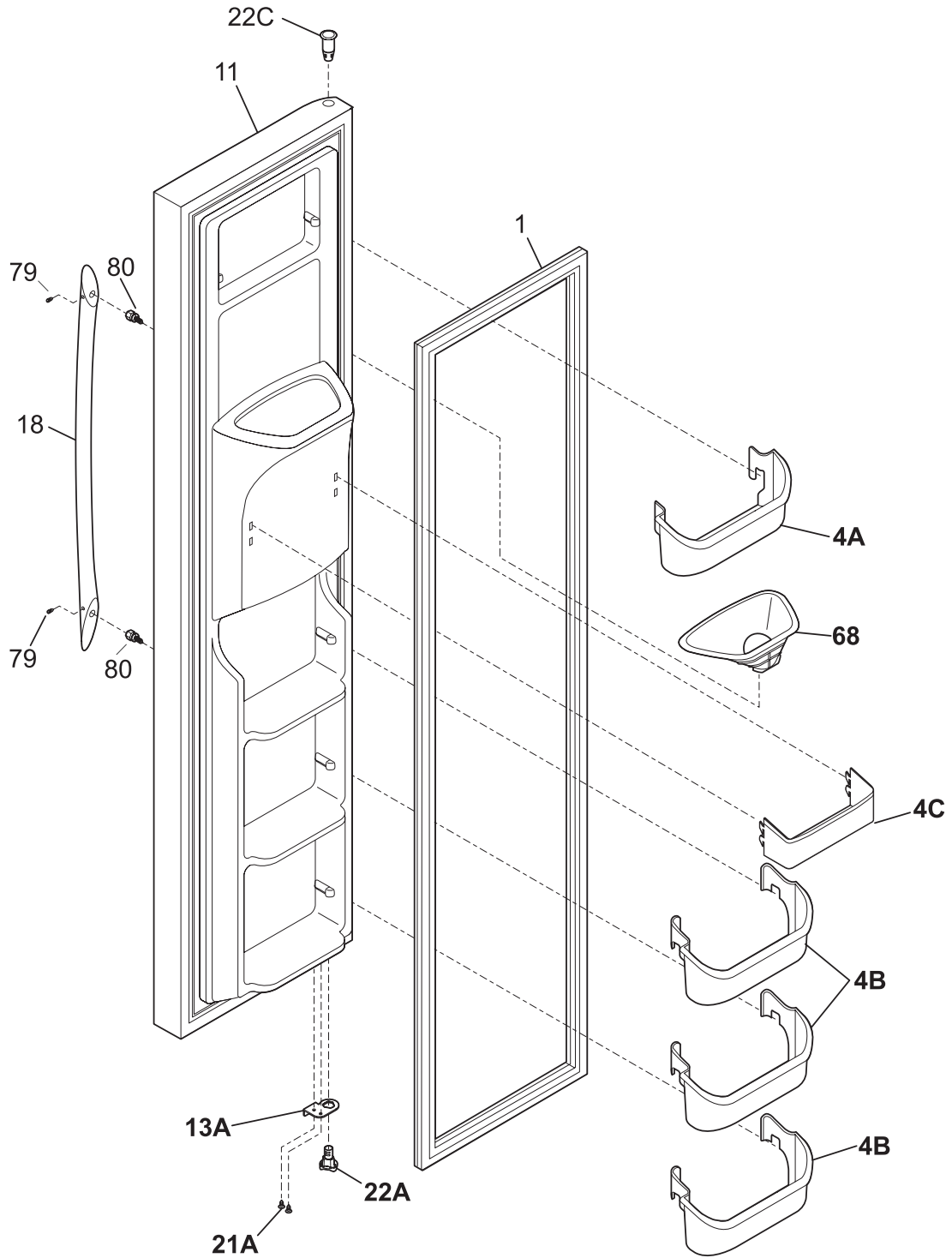

N58FFDBAB1

FREEZER DOOR

Model Index: A WSPZ25V9C (WSPZ25V9CSP)
 B WSPZ25V9C (WSPZ25V9CS7)

POS. NO	PART NO.		DESCRIPTION
1 #	241569808	A B	Gasket-frzr door, black, magnetic
4A	240367302	A B	Bin-door, frzr-upper
4B	240359002	A B	Bin-door
4C	240358402	A B	Bin-door, frzr-dispenser
11	241668535	A -	Door-frzr, stainless, complete assy
11	241526741	- B	Door-frzr, stainless, complete assy
13A	240581906	A B	Door Stop, black, frzr
18	240536805	A B	Handle-door, stainless steel, with insert, and set screw
21A	240598401	A B	Screw, 10-32 x 1/2
22A	240328204	A B	Bearing-hinge(frz), black, closer
22C	240328404	A B	Bearing-hinge, black, upper
68	241525101	A B	Chute-ice
79	218755401	A B	Screw-set, 10-32 x 0.375
80	218755503	A B	Screw-shoulder, #10 AB, handle mounting
*	218490901	A B	Cleaner, stainless steel
*	240352102	A B	Connector-water, straight
*	240470401	A B	Connector-amp
*	240552102	A B	Harness-wiring, door
*	5303918273	A B	Dispenser heater kit, 220

REFRIGERATOR DOOR

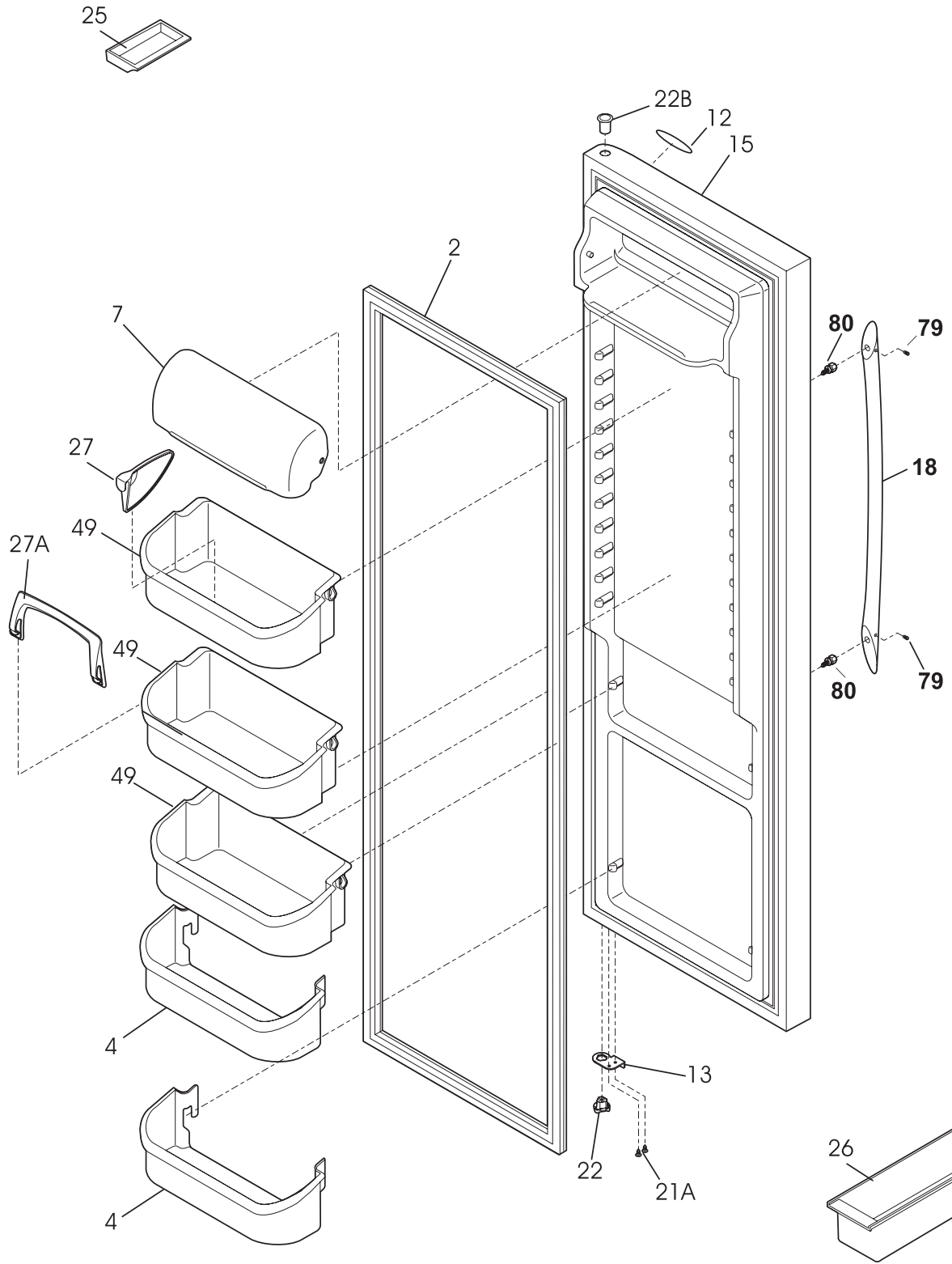

N58RFDCAA0

REFRIGERATOR DOOR

Model Index: A WSPZ25V9C (WSPZ25V9CSP)
 B WSPZ25V9C (WSPZ25V9CS7)

POS. NO	PART NO.		DESCRIPTION
2 #	241569807	A B	Gasket, refr door seal, black, magnetic
4	240363702	A B	Bin-door, 2-liter
7	240338309	A B	Door-dairy
12	240578101	A B	Label-nameplate
13	240581905	A B	Door Stop, black, ref
15	241534527	A B	Door-refr, stainless, complete assy
18	240536805	A B	Handle-door, stainless steel, with insert, and set screw
21A	240598401	A B	Screw, 10-32 x 1/2
22	240328203	A B	Bearing-hinge, black, closer
22B	240328404	A B	Bearing-hinge, black, upper
25	5308000716	A B	Dish, butter
26	3204522	A B	Container, egg
27A	240396102	A B	Retainer, tall bottle
49	240324502	A B	Bin-door, gallon
79	218755401	A B	Screw-set, 10-32 x 0.375
80	218755503	A B	Screw-shoulder, #10 AB, handle mounting
*	218490901	A B	Cleaner, stainless steel

CABINET

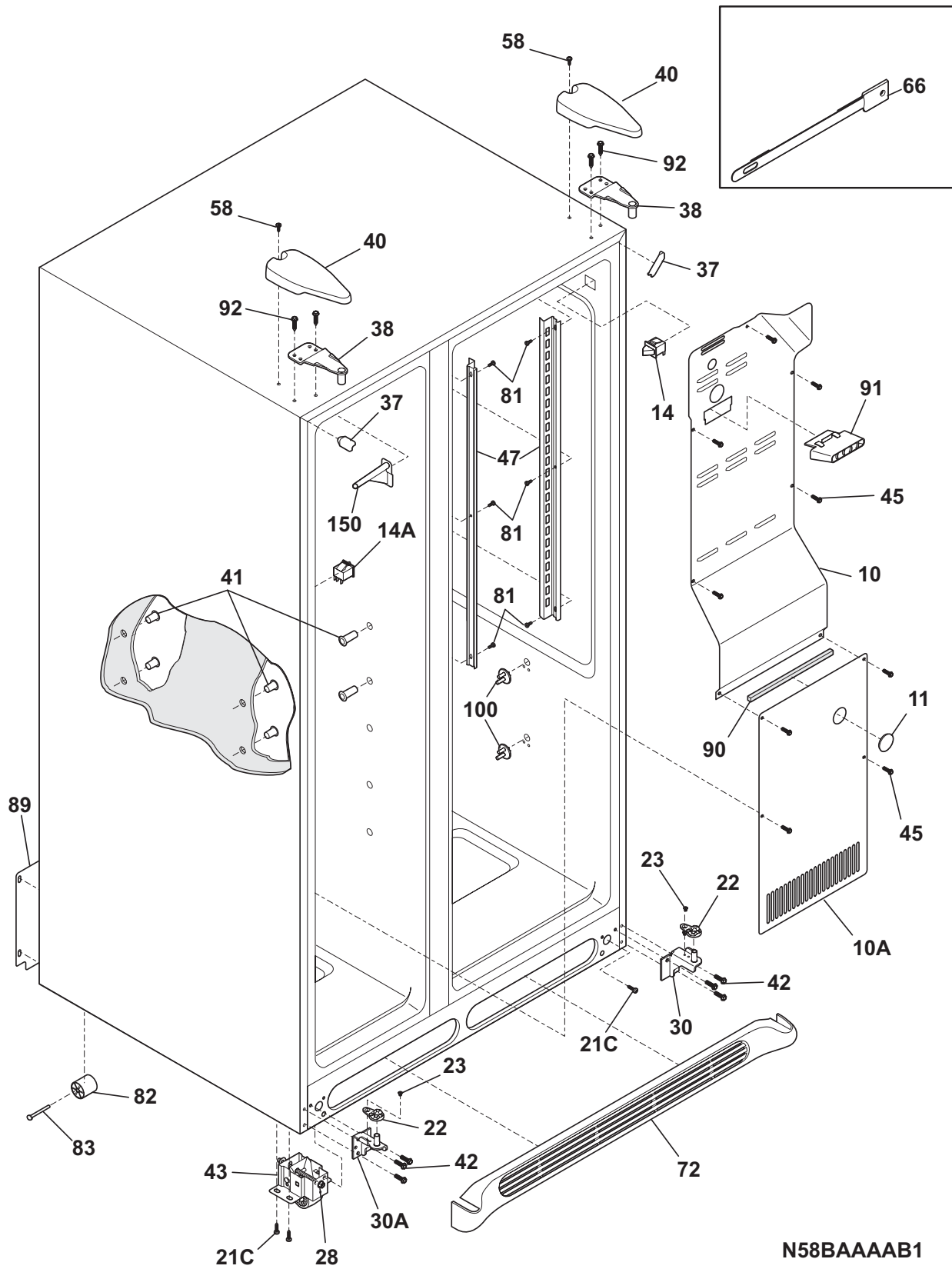

N58BAAAAB1

CABINET

Model Index: A WSPZ25V9C (WSPZ25V9CSP)
B WSPZ25V9C (WSPZ25V9CS7)

POS. NO	PART NO.		DESCRIPTION
10	240435905	A B	Cover-air duct
10A	240475906	A B	Cover-evap coil, lower
11	5303208309	A B	Plug-hole, factory test
14 #	240505801	A B	Switch, light/lamp
14A	241547901	A B	Switch-light/lamp, frzr door
21C	218252200	A B	Screw, #8 truss hd, 10-32CA x 0.500
22	240457702	A B	Plate-door closer
23	240402701	A B	Screw-#10-32 x 1/4 flat hd
28	240335501	A B	Bolt-roller adj, hex washer head, 1/4-20 x 4.020, (2), special
30	241603701	A B	Bracket-lower hinge, ref
30A	241603702	A B	Bracket-lower hinge
37	240337603	A B	Trim-cabinet corner, black, (2)
38	240327201	A B	Bracket-upper hinge
40	240327007	A B	Cover-upper hinge, black
41	241550801	A B	Grommet-shelf mtg, 1.40" long
41*	241550701	A B	Grommet-shelf mtg, .96" long
42	240578901	A B	Screw-hinge mtg, hex head, 1/4-20 x 5/8
43	240335003	A B	Roller Assy, adjustable, front, (2)
45	241500301	A B	Screw, hex washer head, 8-18AB x 0.500
47	240349402	A B	Channel-shelf mtg, side, (2)
58	218781100	A B	Screw, pan head, 8-18 x 0.625
66	5304424968	A B	Damper Cover Assy
66*	240518802	A B	Pin-push, push-in, plastic
72	240324405	A B	Grille/Kickplate, black
81	5308016566	A B	Screw, hex washer head, 8-15A x 0.625, low profile
82	5304418225	A B	Roller, compressor base, rear, (2)
83	5303316859	A B	Rivet, flat head, 1/4 OD x 1-3/4, roller pin
89	240326112	A B	Cover-access, with label
90	218249807	A B	Seal-coil cover
91	240380101	A B	Duct-ice maker
92	216850900	A B	Screw, hex washer hd, 1/4 x 7/8, hinge mtg
100	240423701	A B	Support, crisper cover, front, (4)
100*	240350802	A B	Support, crisper cover, rear, (4)
150	240368701	A B	Guide-control bulb
*	240396801	A B	Clamp, tube/wiring, nylon, black/natural
*	240479601	A B	Plug, button, cab liner holes, (2)
*	240481601	A B	Shim-lower hinge
*	5303305345	A B	Paint, touch-up, black

SHELVES

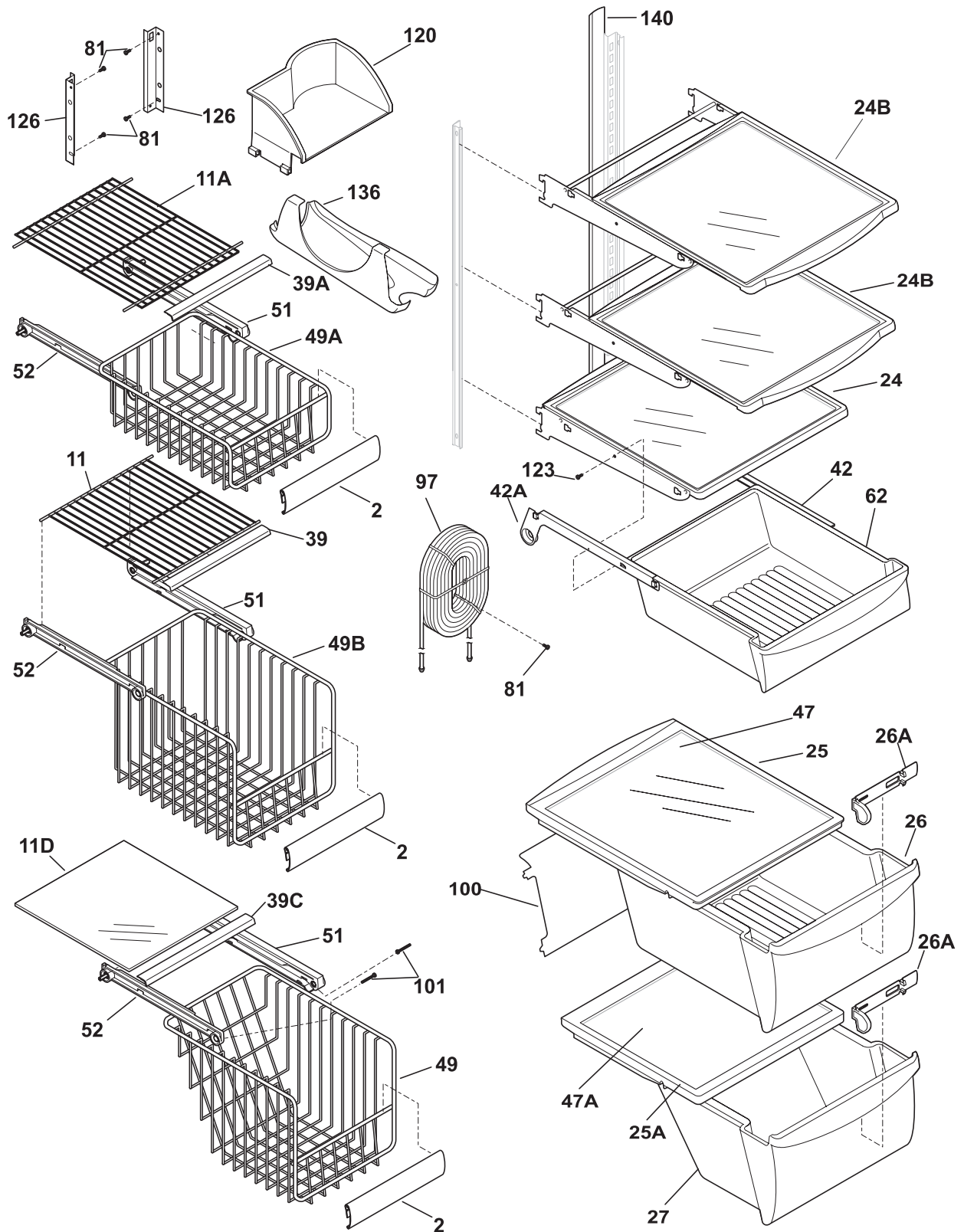

N58SDEEBC1

SHELVES

Model Index: A WSPZ25V9C (WSPZ25V9CSP)
B WSPZ25V9C (WSPZ25V9CS7)

POS. NO	PART NO.		DESCRIPTION
2	241510603	A B	Trim-basket
11	240338801	A -	Shelf-freezer, flip-up
11	241657601	- B	Shelf, flip up, wire
11A	241657503	A -	Shelf, fixed upper, freezer
11A	240338703	- B	Shelf-freezer, fixed wire
11D	240350642	A B	Shelf-freezer, glass
24	240355230	A B	Shelf-"Spill-Safe", fixed
24B	240350124	A B	Shelf-"Spill-Safe", cantilever, sliding
25	240354502	A B	Cover-crisper pan, upper
25*	240362101	A B	Clip-slide, cover-crisper
25A	240354602	A B	Cover-crisper pan, lower
26	240354711	A B	Pan-crisper, upper
26*	240349801	A B	Clip-slide, pan-crisper
26A	240351101	A B	Control-humidity
27	240354812	A B	Pan-crisper, lower
39	240430705	A B	Trim-shelf, front
39A	240430701	A B	Trim-shelf, front
39C	240367601	A B	Trim-shelf, front
42	240356501	A B	Track, meat pan hanger, RH
42A	240349701	A B	Hanger-meat pan, LH
42A*	240349901	A B	Block-meat pan rail, LH
42A*	240350001	A B	Spring-meat pan rail
42A*	240356701	A B	Seal-meat pan
47	240443302	A B	Insert-pan cover, glass, upper
47A	240350614	A B	Insert-pan cover, glass
49	240530401	A B	Basket-sliding
49A	240530501	A B	Basket-sliding, upper, half
49B	240530503	A B	Basket-sliding, upper, full
51	240343002	A B	Hanger-basket, RH
52	240343102	A B	Hanger-basket, LH
62	240355510	A B	Pan-meat
81	5308016566	A B	Screw, hex washer head, 8-15A x 0.625, low profile
97	240545303	A B	Water Tank Assy, coiled tubing, front filter
100	240326301	A B	Cover-water tank
101	218493100	A B	Screw, hex washer head, 8-18AB x 1-3/4
120	240342901	A B	Shelf-ice cream
123	215005100	A B	Screw, hanger/r/r mtg, 8-10 x 0.438
126	241630701	A B	Channel, auger mtg, LH
126	241630702	A B	Channel, auger mtg, RH
136	240424501	A B	Dispenser-can, white
140	240430501	A B	Channel, wtr tube cover

CONTROLS

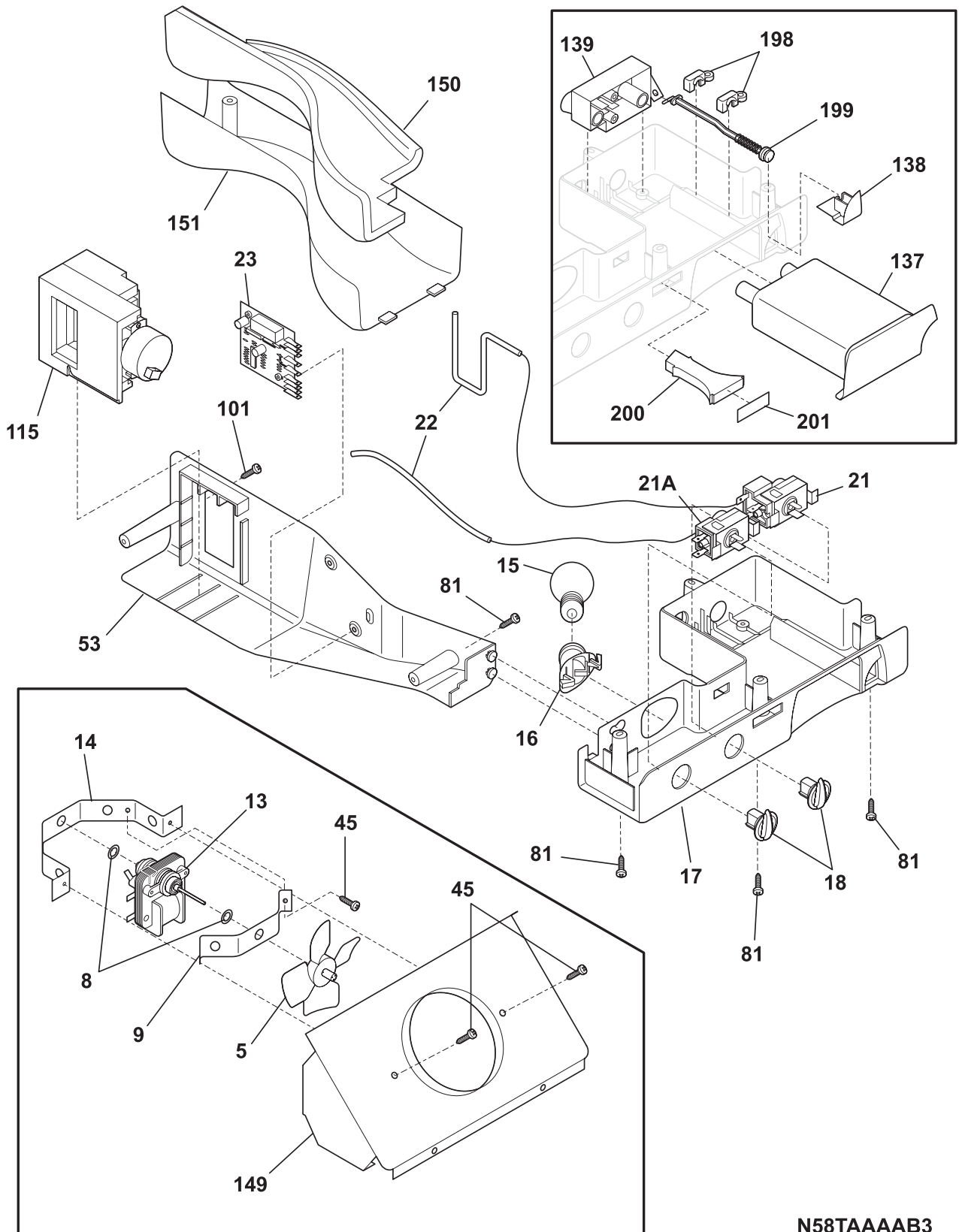

N58TAAAAB3

CONTROLS

Model Index: A WSPZ25V9C (WSPZ25V9CSP)
 B WSPZ25V9C (WSPZ25V9CS7)

POS. NO	PART NO.		DESCRIPTION
5 #	5308000010	A B	Fan Blade, red, evaporator fan
8	215474201	A B	Washer, "slinger", nylon, evap fan shaft
9	241563601	A B	Bushing-motor mtg, (2)
13 #	240419601	A B	Motor-evap fan, 220V
14	241517701	A B	Clip, evap fan motor
15	218814400	A B	Light Bulb/Lamp
16	218971501	A B	Socket-light/lamp
17	240374903	A B	Box-control, front
17*	215188300	A B	Screw-control box mtg, hex head, 8-15A x 1.000, refr/frzr
17*	241508101	A B	Harness-wiring, control box
18	240360801	A B	Knob, temp control
21	241586502	A B	Control-temperature
21A#	5304424386	A B	Control-temperature, frzr section
22	218660702	A B	Tube-insulator
23	241508002	A B	Control-defrost, adaptive timer, PC board
53	240369501	A B	Box-control
81	5308016566	A B	Screw, hex washer head, 8-15A x 0.625, low profile
101	218493100	A B	Screw, hex washer head, 8-18AB x 1-3/4
115	241600903	A B	Damper Assy, w/seal
137	240396403	A B	Filter, water, carbon cassette, front, with o'rings
137*	240396701	A B	Bypass, water filter, Optional Part
138	240397301	A B	Button-filter release
139	240396001	A B	Base-water filter
139*	240526901	A B	O-ring, wtr filter base
149	241563401	A B	Shroud-fan orifice
149*	241528305	A B	Seal, shroud
150	240394203	A B	Insulation-water tube cover
151	240373805	A B	Cover-water tube
198	240397401	A B	Retainer
199	240397501	A B	Rod
199*	240398401	A B	Spring-filter release rod
200	240397601	A B	Light Pipe
201	240398507	A B	Label-control box
*	240410601	A B	Shield-light, refr
*	240427202	A B	Heater-freezer control
*	240470401	A B	Connector-amp

SYSTEM

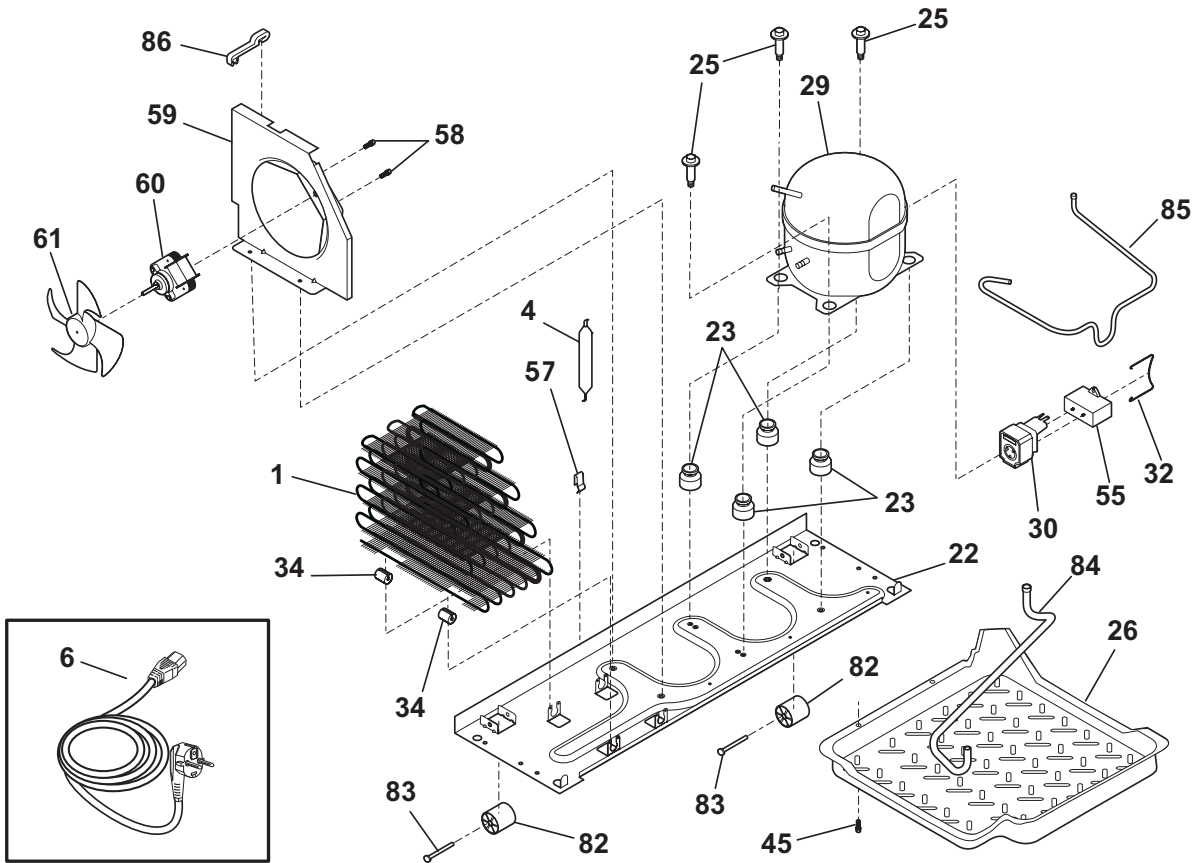
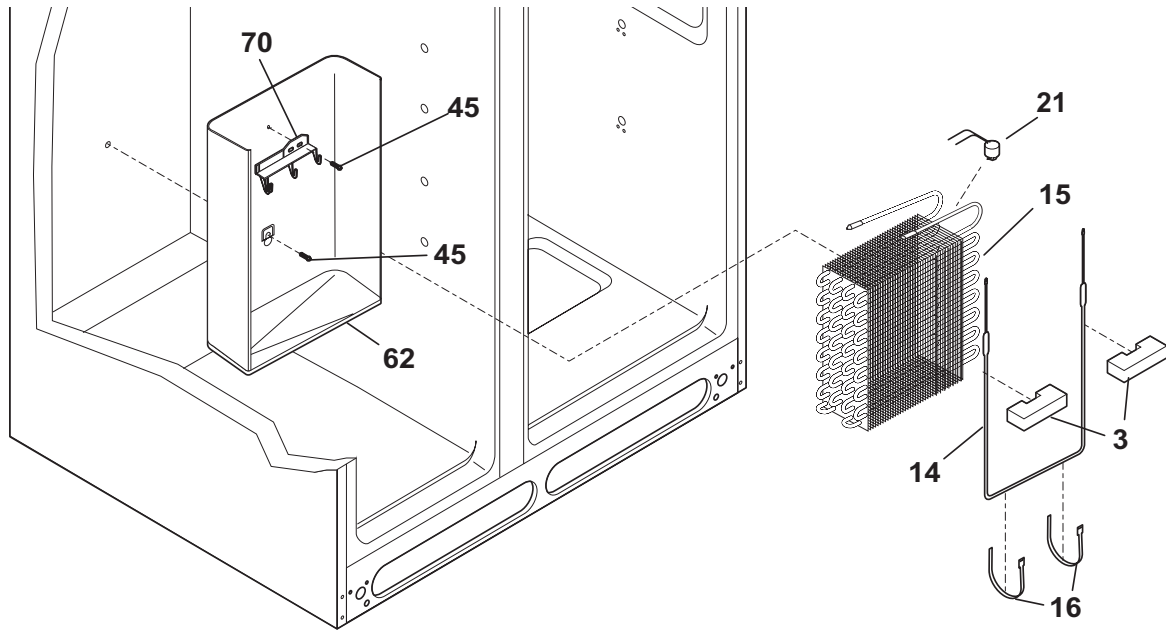

N58CAAABA2

SYSTEM

Model Index: A WSPZ25V9C (WSPZ25V9CSP)
 B WSPZ25V9C (WSPZ25V9CS7)

POS. NO	PART NO.		DESCRIPTION
1	240333602	A B	Condenser
3	218679606	A B	Block-evap coil, styrofoam, (2)
4 #	218944001	A B	Drier-filter, R134a System
6	240449501	A B	Cord-electric power
6*	240447101	A B	Bracket, strain relief
6*	240447201	A B	Clamp, strain relief
6*	241627301	A B	Harness-wiring, machine compt
6*	241508101	A B	Harness-wiring, control box
6*	241651601	A B	Harness-wiring
14 #	5303918308	A -	Defrost Heater Kit, 220 V
14 #	5303918245	- B	Defrost Heater Kit, 220
15 #	5303918286	A B	Evaporator Kit
16	5308000110	A B	Strap-evap/heater, aluminum, (2)
21	5303918202	A B	Thermostat-defrost, kit
22	240330007	A B	Base-compressor mtg
22*	218252200	A B	Screw, #8 truss hd, 10-32CA x 0.500
23	218513300	A B	Grommet-compr mtg, (4)
25	240491501	A B	Screw-compressor mtg, 1/4-28 x 1.16, shoulder, typ CF
26	241637401	A B	Pan-defrost
29 #	5303918320	A B	Compressor, w/electricals
30	241524609	A B	Starter-PTC
32	240553401	A B	Clamp, elec cont mtg, compressor
34	240405201	A B	Grommet, rubber, black, cond tube/wire
45	5308016566	A B	Screw, hex washer head, 8-15A x 0.625, low profile
55 #	218909908	A B	Capacitor, run
57	240542601	A B	Clip-wiring harness
58	215004600	A B	Screw, hx serr wshr hd, 8-36 x 7/16, cond fan motor, (2)
59	5304430246	A B	Bracket-cond motor assy
59*	240346701	A B	Tape-foam seal, shroud
59*	240359401	A B	Screw-fan shroud, (2)
60 #	240525403	A B	Motor-condenser fan
61 #	240524101	A B	Fan Blade, galv steel, condenser fan
62	240429401	A B	Trough-drain
70	218990801	A B	Bracket-evap/cvr mtg
82	5304418225	A B	Roller, compressor base, rear, (2)
83	5303316859	A B	Rivet, flat head, 1/4 OD x 1-3/4, roller pin
84	5304421068	A B	Tube-drain, lower
85	240553501	A B	Tube-connector, suction
86	240409302	A B	Spacer-cond tube, black
* #	5303918213	A B	Heat Exchanger Kit, suction line
*	5303918244	A B	Hot Tube Repair Kit, service

ICE & WATER DISPENSER

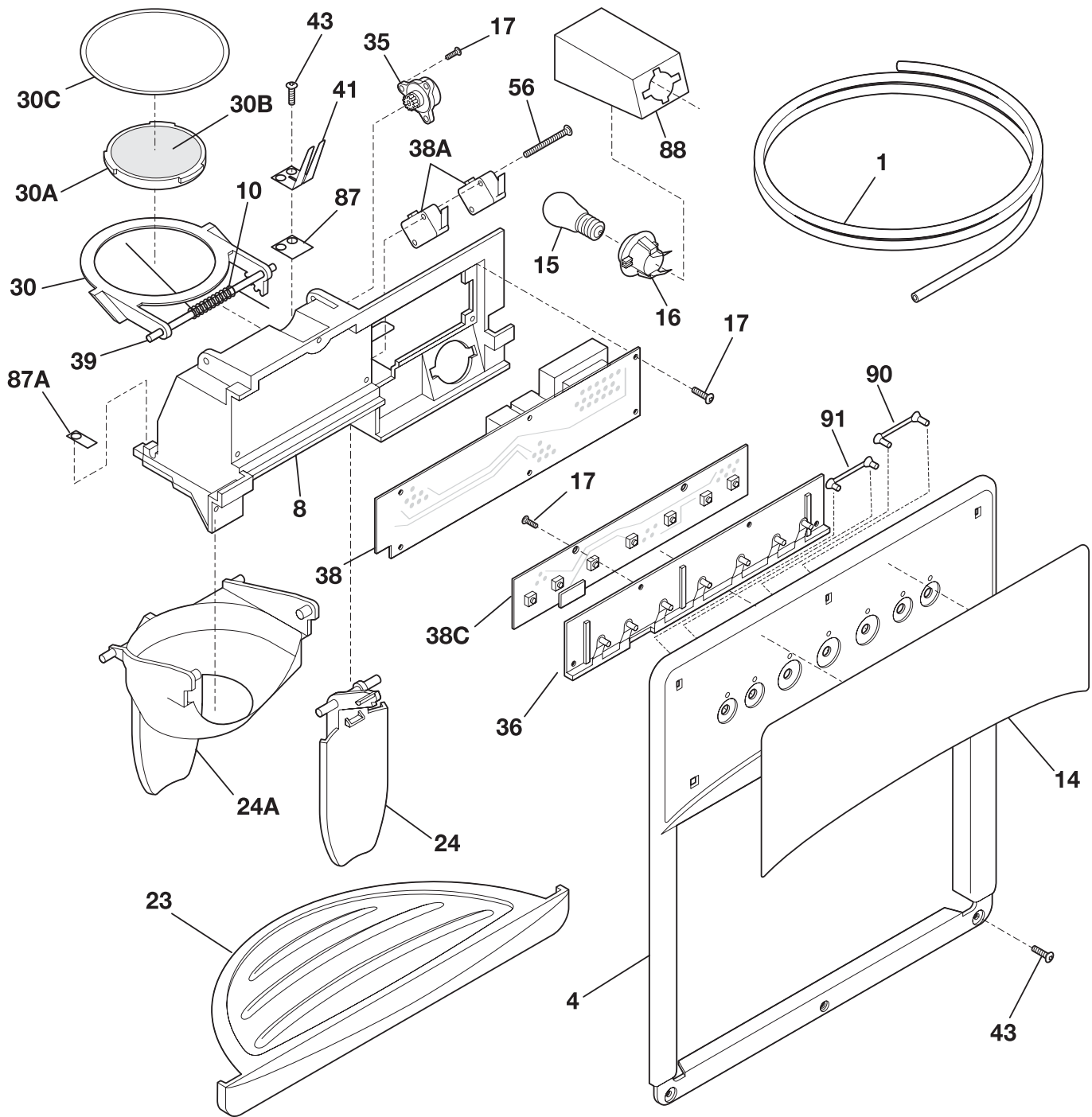

N58XBAAAB0

ICE & WATER DISPENSER

Model Index: A WSPZ25V9C (WSPZ25V9CSP)
 B WSPZ25V9C (WSPZ25V9CS7)

POS. NO	PART NO.		DESCRIPTION
1	218976409	A B	Tube-water-DOOR
1*	218976901	A B	Tube-water inlet, inlet valve, to ice maker
1*	218976903	A B	Tube-water inlet, inlet valve, to filter
1*	218976907	A B	Tube-water inlet, valve to door
1*	240561701	A B	Seal-water inlet, inlet valve, to ice maker
4	5304422012	A B	Cover-module, black
8	5304422013	A B	Module-dispenser
10	5304421626	A B	Spring-torsion
14	240323937	A B	Label-module cover, black
15	218557200	A B	Light Bulb/Lamp
16 #	215621500	A B	Receptacle, E-14 lampholder, 50/60 Hz, 250 V, IEC
17	5304421619	A B	Screw
23	241649003	A -	Drip Tray, black
23	240323603	- B	Drip Tray, black
24	5304422026	A B	Actuator-water, black
24A	5304422025	A B	Actuator-ice, black
30	5304421628	A B	Door Assy-ice chute
30A	5304421624	A B	Door center
30B	5304421625	A B	Insulation-door
30C	5304421629	A B	Door seal
35	5304421620	A B	Damper-rotary
36	5304421824	A B	Carrier
38	5304426548	A B	Power Board
38A#	5304421617	A B	Switch-micro, single pole, double throw
38C	5304426008	A B	Board-control
38C*	218515401	A B	Clip
39	5304421627	A B	Pin-hinge
41	5304421829	A B	Spring-actuator
43	215296300	A B	Screw, plask h/l, #6 x 3/8
56	5304421830	A B	Screw-micro switch, pan head
87	5304421622	A B	Bearing Plate
87A	5304421621	A B	Bearing Plate
88	5304421615	A B	Shield-light
90	5304421831	A B	Light Pipe, reflector
91	5304421850	A B	Light Pipe, reflector, short
*	5303918273	A B	Dispenser heater kit, 220
*	5304426535	A B	Insulator-electrical

ICE CONTAINER

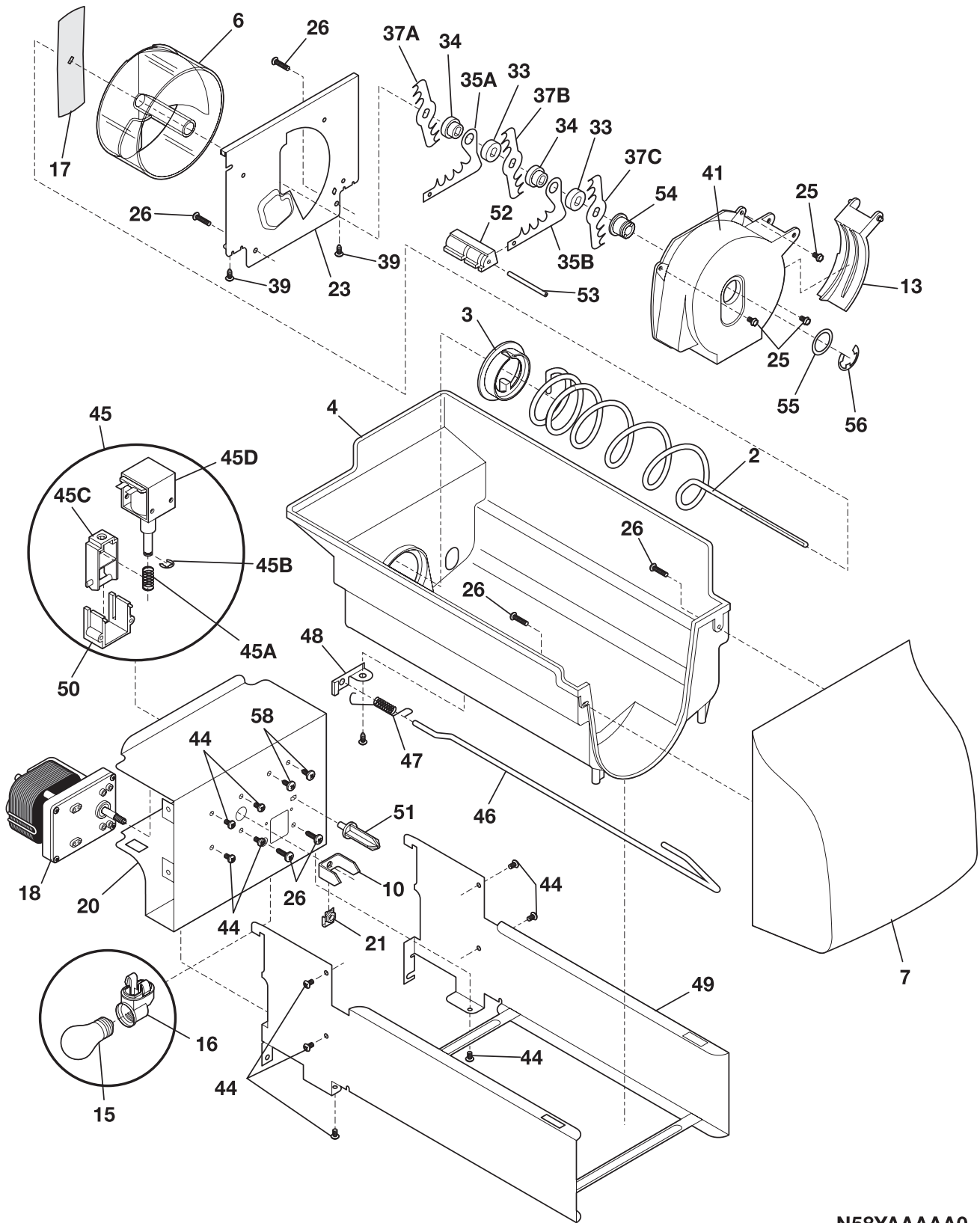

N58YAAAAA0

ICE CONTAINER

Model Index: A WSPZ25V9C (WSPZ25V9CSP)
B WSPZ25V9C (WSPZ25V9CS7)

POS. NO	PART NO.		DESCRIPTION
2	5304428402	A B	Auger-ice
3	5304404343	A B	Cam-drive
4	218815300	A B	Container-ice, bucket only
6	5304404346	A B	Drum-ice disp
7	5304422805	A B	Front-ice container
10	5304404337	A B	Bar-drive
13	5304404359	A B	Gate
15	218814400	A B	Light Bulb/Lamp
16	240433701	A B	Receptacle, E27A lampholder, 115 V
17	5304404345	A B	Drive Blade
18	5304440990	A B	Motor-auger
18*	5304404335	A B	Wiring Harness, auger motor
18*#	240352601	A B	Wiring Harness, internal, with plug
20	5304404332	A B	Cover-motor
21	215285100	A B	Nut-drive
23	5304404347	A B	Plate-front
25	5304404362	A B	Screw, hex washer head, 8-32T x 0.375
26	215503200	A B	Screw, cr pan hd, 10-16 x 0.500
33	5304404351	A B	Spacer
34	5304404349	A B	Spacer
35A	5304404353	A B	Fixed Blade, round
35B	5304404352	A B	Fixed Blade, square
37A	5304404348	A B	Blade, crusher #1
37B	5304404350	A B	Blade, crusher #2
37C	5304404356	A B	Blade, crusher #3
39	5304404365	A B	Screw
41	5304404358	A B	Housing-crusher
44	218359200	A B	Screw, pan head, 8-32 x 0.250
45 #	5304406815	A B	Solenoid Assy, 220 V
45A	5304406816	A B	Spring-solenoid
45B	5304406817	A B	E-Ring-solenoid
45C	5304406818	A B	Actuator-solenoid
45D#	5304406820	A B	Solenoid, 220 V
46	5304404341	A B	Control Rod
47	5304404342	A B	Spring-control rod
48	5304404340	A B	Bracket-control rod
48*	5304404364	A B	Screw-bracket
49	5304404880	A B	Rail Assy
50	5304404334	A B	Guide-solenoid
51	5304404336	A B	Rotation Stop
52	5304404354	A B	Spacer-fixed blades
53	5304404355	A B	Pin-spiral, fixed blades
54	5304404357	A B	Nut-auger
55	5304404360	A B	Washer
56	5304404361	A B	E-ring
58	5304404331	A B	Screw-solenoid
*	218817301	A B	Shield-light
*	240323806	A B	Ice Container Assy, w/moving parts

ICE MAKER

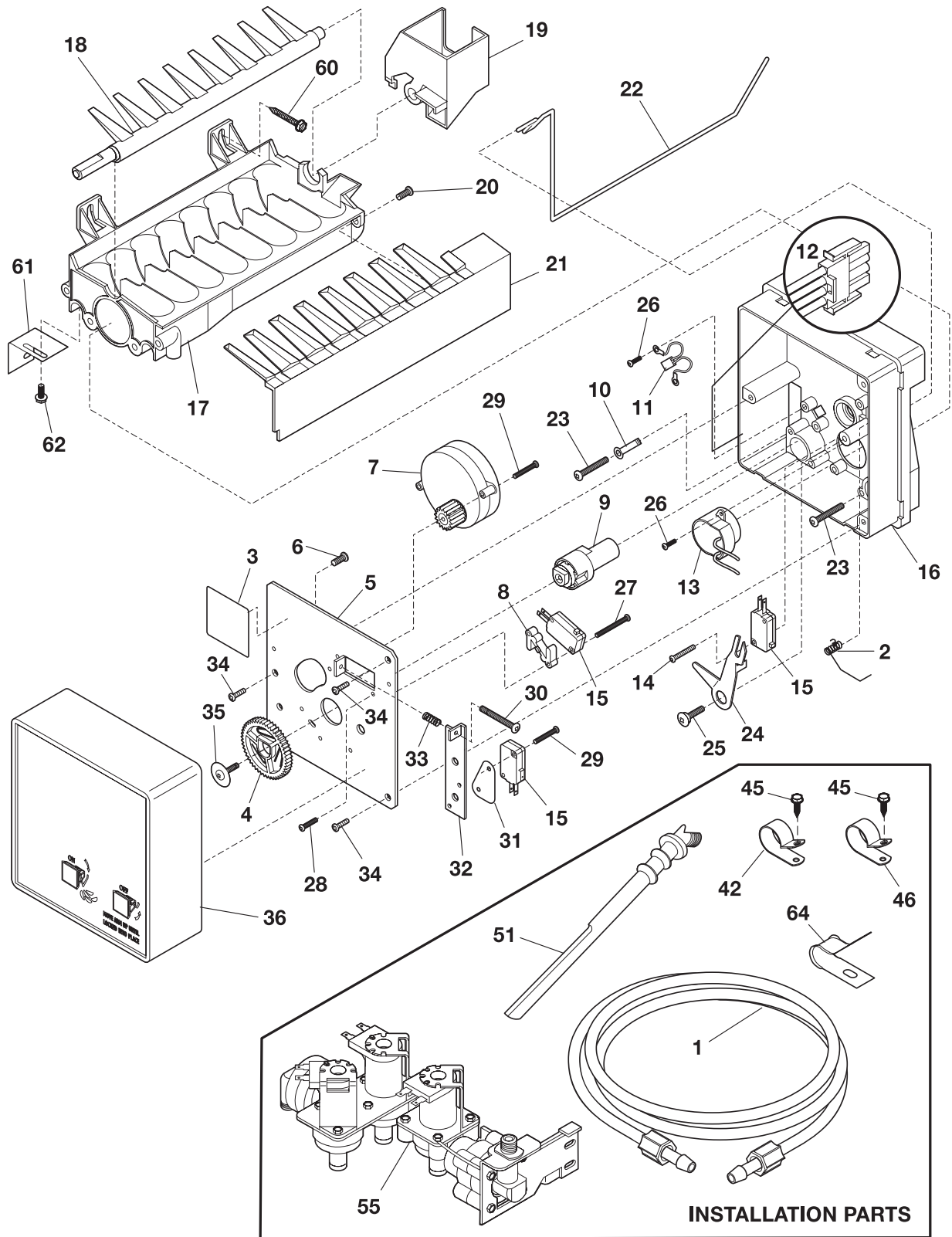

N58I115

ICE MAKER

Model Index: A WSPZ25V9C (WSPZ25V9CSP)
 B WSPZ25V9C (WSPZ25V9CS7)

POS. NO	PART NO.		DESCRIPTION
1	218976409	A B	Tube-water-DOOR
1*	218976901	A B	Tube-water inlet, inlet valve, to ice maker
1*	218976903	A B	Tube-water inlet, inlet valve, to filter
1*	218976907	A B	Tube-water inlet, valve to door
1*	240561701	A B	Seal-water inlet, inlet valve, to ice maker
2	5304420650	A B	Spring, shut-off arm
3	5303210334	A B	Plate-I.D.
4	3206301	A B	Gear
5	3206303	A B	Plate-mounting
6	3206305	A B	Screw-ground wire, 8-32 x 0.250
7 #	5303210332	A B	Motor-ice maker
8	3206312	A B	Spacer-hold switch
9	3206313	A B	Cam
10	3206315	A B	Clamp
11 #	3206319	A B	Thermal Cutoff, ICE MAKER, complete assy
12 #	240352601	A B	Wiring Harness, internal, with plug
13 #	3206322	A B	Thermostat Assy, ICE MAKER
14	5304420652	A B	Screw, 4 x 0.750, switch mtg.
15 #	3206324	A B	Switch, (3)
16	5304420653	A B	Support, phenolic
17 #	5304420711	A B	Mold-ice maker, Radius Cube, 220V, with heater
18	3206328	A B	Ejector-ice
19	5304408580	A B	Cup-water inlet, w/bearing
20	5304408581	A B	Screw, 8-32 x 0.375
21	3206332	A B	Ice Stripper
22	3206333	A B	Shut-off Arm
23	5304408582	A B	Screw, 8-32 x 0.875, mold-to-support, (3)
24	3206335	A B	Lever Arm
25	3206336	A B	Screw, 8-18 x 0.562, lever arm/sprt
26	5304420654	A B	Screw-thermo/sprt, 4-24 x 0.375, (4)
27	3206338	A B	Screw, 4-40 x 1.000, hold switch mtg, (2)
28	3206339	A B	Screw-timing stop, 4-40 x 0.375
29	3206323	A B	Screw, 4-24 x 0.750, (6)
30	3206341	A B	Screw-timing adj, 8-32 x 1.000
31	3206342	A B	Insulator
32	3206343	A B	Plate-valve switch
33	5304408583	A B	Spring-timing adj
34	5304420655	A B	Screw, plazscrew, 8-10, (3)
35	5304408585	A B	Screw
36	3206347	A B	Cover-ice maker
42	5303001199	A B	Clamp-wiring harness, strain relief, galv steel
42*	218515402	A B	Clip, (2), tube mtg.
45	5303001343	A B	Screw, hex washer head, 8-15A x 0.500
45*	5308016566	A B	Screw, hex washer head, 8-15A x 0.625, low profile
46	5308000133	A B	Clamp, nylon, .625 ID
51	240387101	A B	Tube-water, ice mold fill, extension
55	240536201	A B	Valve-water, triple solenoid, 220
55*	240542901	A B	Cap-water valve
60	5303207328	A B	Screw, hex washer head, 8-15A x 1.000, (2)

ICE MAKER

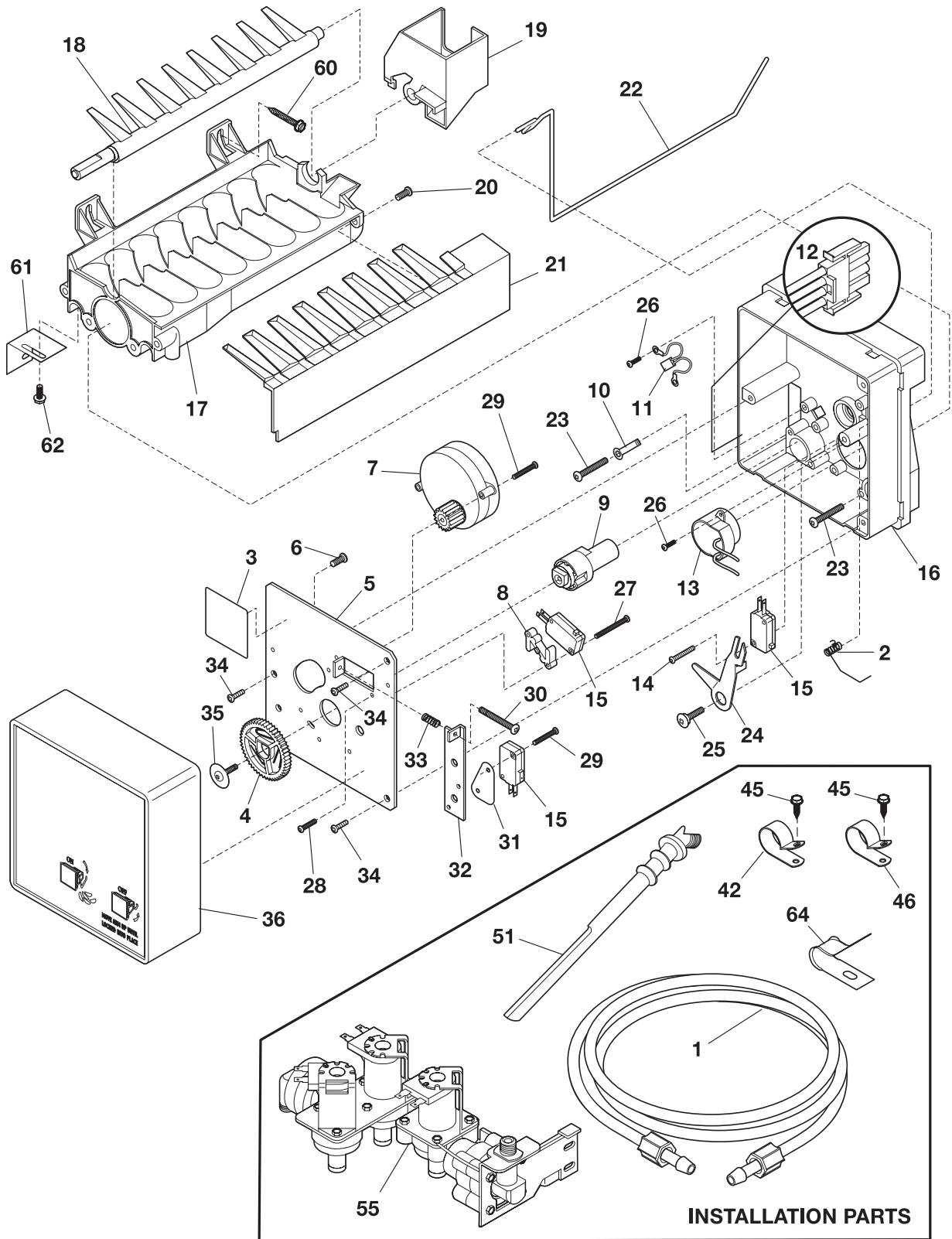

N58I115

ICE MAKER

Model Index: A WSPZ25V9C (WSPZ25V9CSP)
 B WSPZ25V9C (WSPZ25V9CS7)

POS. NO	PART NO.		DESCRIPTION
61	218721500	A B	Bracket-leveling, ICE MAKER
64	5303001549	A B	Clamp, 0.31 ID, steel, copper wtr line
66	5304436611	A B	Bracket-ice maker
67	5304436612	A B	Switch, on/off
*	218888001	A B	Adapter-water supply, nut & sleeve, compression ftg
*	240352412	A B	Ice Maker, Radius Cube, 220 V, no instl parts
*	5308000247	A B	Saddle Valve Kit
*	241583301	A B	Deflector-air, ICE MAKER

WIRING SCHEMATIC

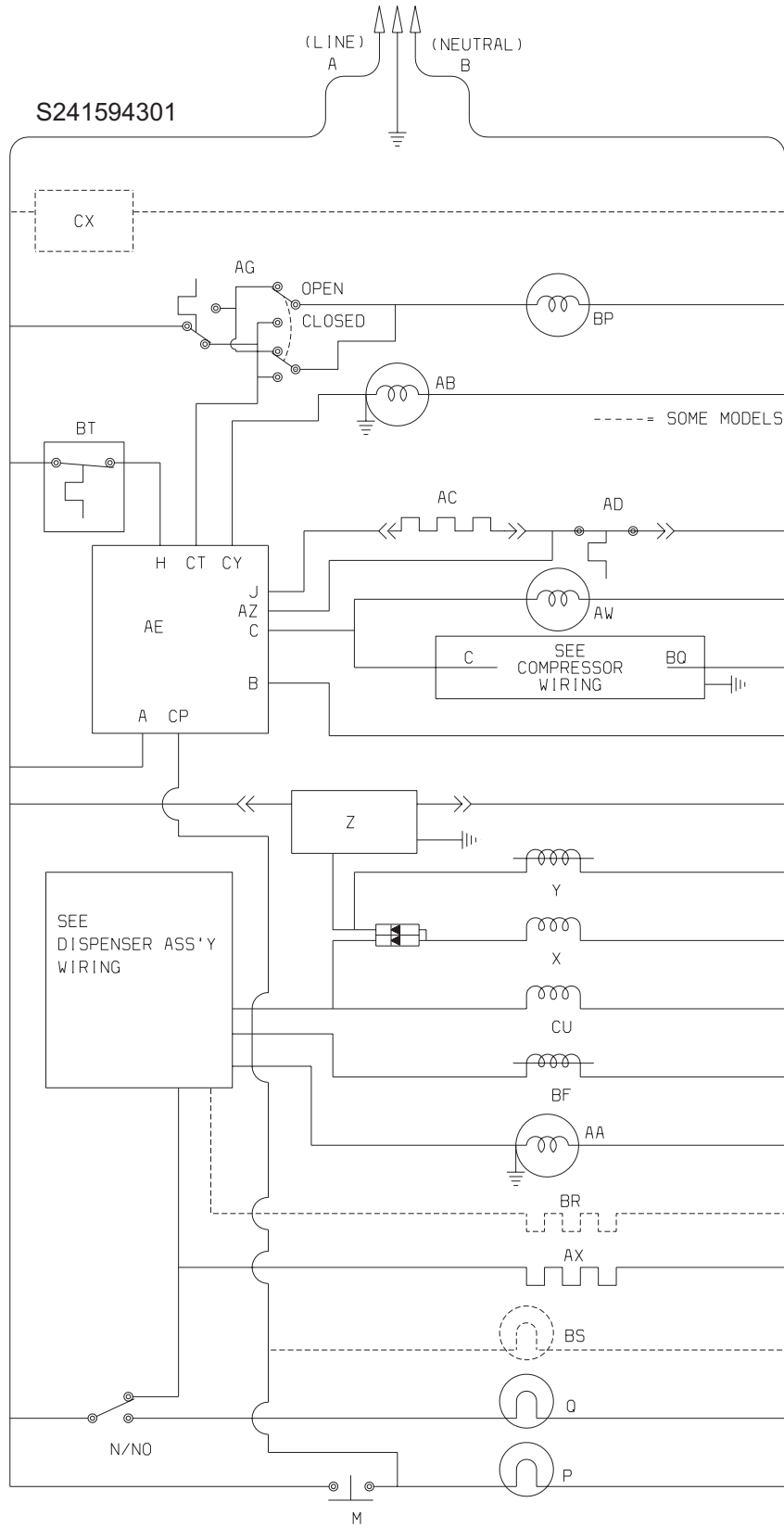

WIRING DIAGRAM

